

Summary

Wiring.....	2
Connector.....	3
Kill Switch.....	4
Setup Mode.....	5
Troubleshooting WiFi connection.....	6
Ignition Timing.....	10
Pickup Type.....	11
Pickup voltage.....	12
VR pickup.....	13
Hall Sensor.....	14
Pickup Position.....	18
Strokes.....	19
Shaft.....	20
Advance Timing.....	21
Select curve.....	22
Read.....	23
Dump.....	24
Modification.....	25
Add points.....	26
Clear points.....	27
Clear Timing.....	28
Clear All.....	29
Factory Restore.....	30
Advanced settings.....	31
Advance at kick start.....	31
AutoSpark.....	32
Kick Speed.....	33
DC-CDI.....	34
Test Point.....	35
Console.....	36
Troubleshooting.....	38
Running Mode.....	39
Appendix 1.....	40
Appendix 2.....	41
Appendix 3.....	42
Appendix 4.....	45

Wiring

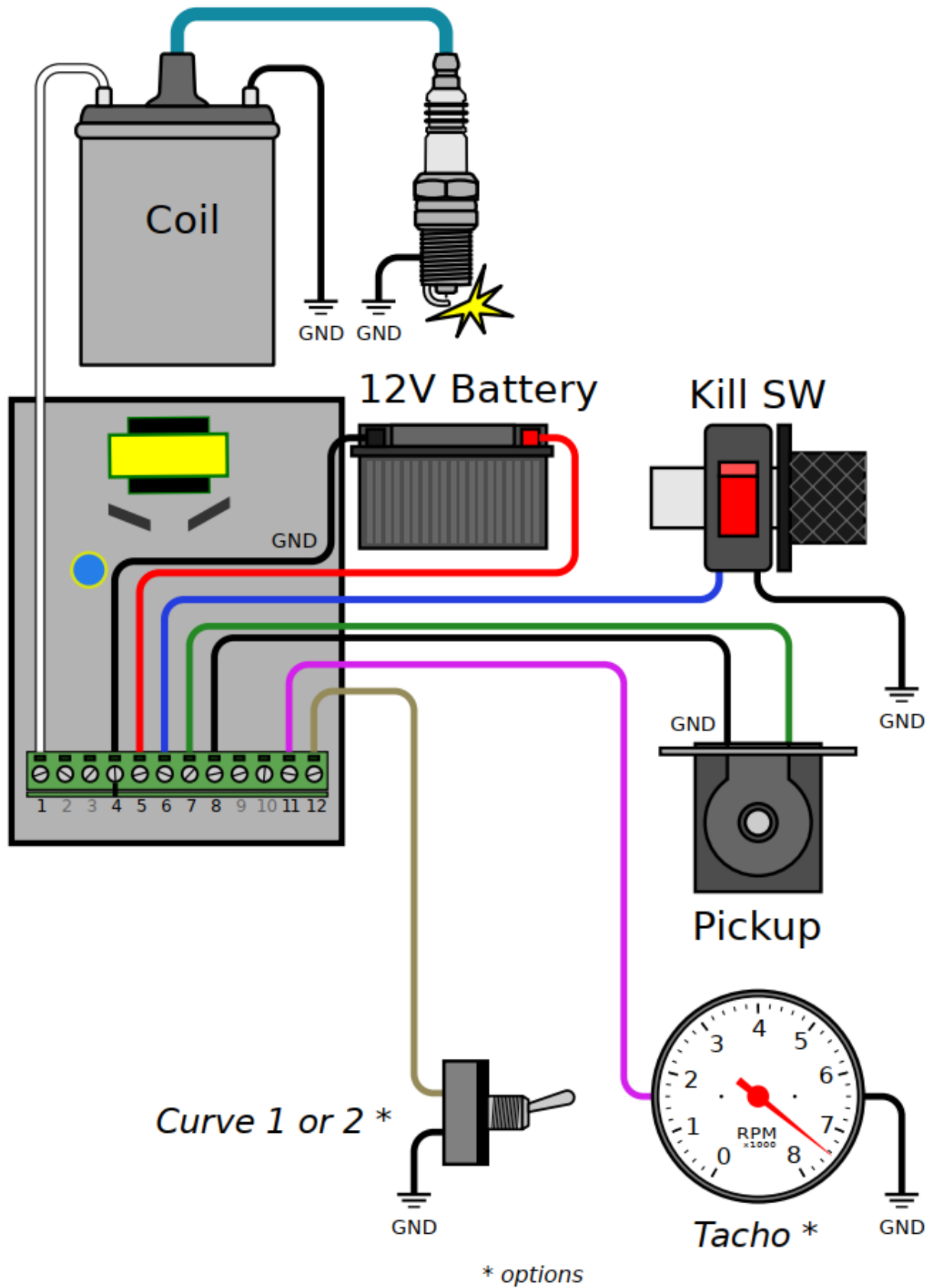

Connector



1	output	To ignition coil	
2	output	To ignition coil	<i>(pin1 and 2 are connected together)</i>
3	output	<i>not connected</i>	<i>(Test Point to measure HighVoltage)</i>
4	input	Ground frame (=minus from battery)	
5	input	+12Vdc from battery	
6	input	Kill switch	
7	input	Analog Pickup	
8	input	Pickup or Hall Sensor Ground	
9	input	Digital Hall Effect Sensor *	
10	input	<i>not connected</i>	<i>(Except for XT600: Pickup at 12°)</i>
11	output	Tachometer *	
12	input	Curve Selection *	

** Options*

Kill Switch

The ignition uses the Kill switch input as a selector between 2 functions:

- Setup
- Stop engine.

Setup Mode

1) Turn the **Kill Switch ON** (*connector pin6 connected to ground*) **PRIOR** to power on the ignition box.

2) **Power on** the ignition box with a 6 to 12v battery.

Warning: The Power and Ground connections MUST BE SECURE.
A power outage during the setup process may cause the ignition box to brick !

When the ignition box detects that the kill switch is already grounded, it turns into SETUP Mode.

3) The **Led** blinks 5 times meaning grounded Kill switch has been detected.

Then wait for the WiFi server to start,

then blinks 5 times again meaning "*Wifi Ready*" and finally flashes once every 5 seconds.

4) Turn the **Kill Switch OFF**

5) The ignition box starts a **Wifi AP** (Access Point)

6) On your phone, laptop, PC, whatever, go to the **Wifi setting** and search for a new SSID called **Transmic_ign**

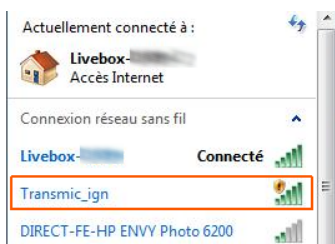

7) **Connect** to it. Password is required: it's "*password*"

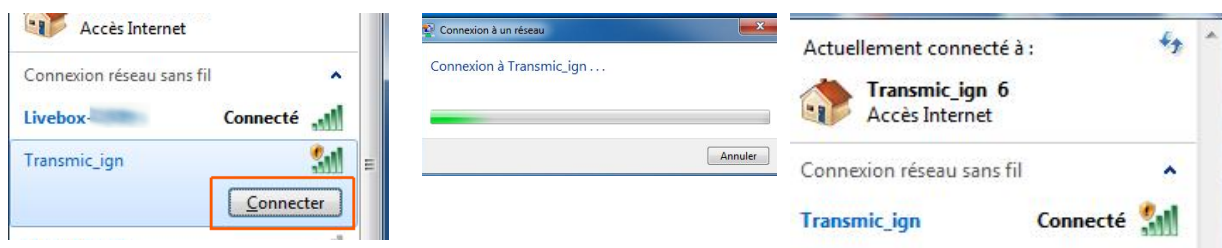

8) Once your device is connected to the AP, open up a **browser** and head over to **http://192.168.4.1/setup** (**http not https !**)

9) Once connected your browser should display:

TRANSMIC.FR

<MODEL> <VERSION>

You are now connected
to your ignition box.
Options: 5
Serial: 2301 ©

[Configuration](#)

Troubleshooting WiFi connection

- Check that the 12pins connector is FULLY inserted and there is nothing preventing the male connector from fully engaging.



- Reboot the ignition box. (Power off/power up)

- Ignore any browser message saying it's not connected to internet. It's not an Error, it's a Warning:

ie: Firefox on W10:



Iphone11:



Indeed, **it's connected ONLY to the Ignition box, not to the web.**
(It's impossible to reach Google and the ignition box at the same time)

- You can see available SSID with a WiFi Monitor as [Wifi Analyzer for Android](#) or [Wifi-Analyzer for W10](#)

- You can test the network connection from your laptop to the ignition box:

Open a command Prompt:

Type "*cmd*" into the address bar of File Explorer and hit Enter
or Press Windows+R to open "*Run*" box. Type "*cmd*" and then click "*OK*"

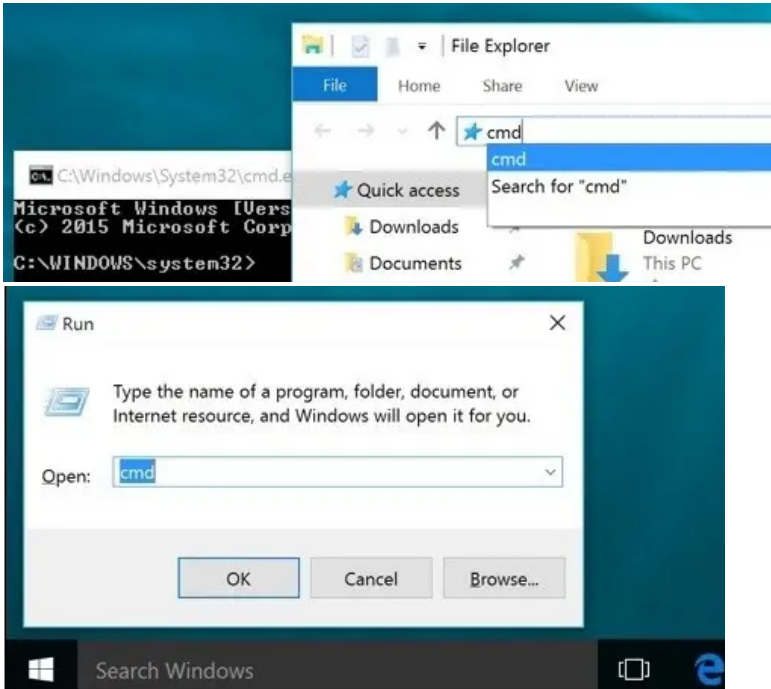

ping the ignition box, it should replies:

```
C:\>ping 192.168.4.1
```

Pinging 192.168.4.1 with 32 bytes of data :

```
Reply from 192.168.1.1 : bytes=32 time<1ms TTL=64
```

```
Reply from 192.168.1.1 : bytes=32 time<1ms TTL=64
```

```
Reply from 192.168.1.1 : bytes=32 time<1ms TTL=64
```

Clear DNS cache

Windows:	in MsDos console:	<code>C:\>ipconfig /flushdns</code>
MacOS:	in Terminal :	<code>sudo dscacheutil -flushcache</code>
Linux:	in Terminal:	<code>sudo systemd-resolve --flush-caches</code>

Troubleshooting display

Console URL is **http://** NOT **https://** but some browsers like Chrome automatically switch to secure https://

- Or use Firefox. Close all Firefox windows than relaunch it.
- Or use a lightweight, portable browser as [QtWeb](#)
- or [disable HSTS](#) In Chrome.

iPhone won't connect to Wifi AP

You may be not prompted for a password.

Apple devices try "weak" passwords in the background !

If the Iphone is connected to SSID "Transmic_ign" (Check mark below) that means it guessed the right pwd.

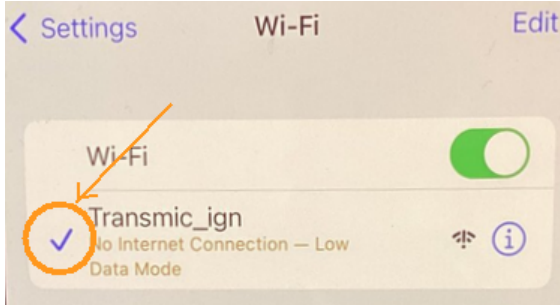

1) Disconnect Cellular data

2) Forget the "transmic_ign" SSID and connect to it again:

<https://youtu.be/yQKFOLIKlqo?si=A0CFfJYSo3uqEjml&t=18>

3) Remove interworking from the wifi configuration:

Settings > Cellular Data > Wi-Fi Calling: Off

4) Disable the automatic switch to mobile data when Wi-Fi connectivity is "poor"

Settings > Mobile Service > Wi-Fi Assist: off

<https://youtu.be/yQKFOLIKlqo?si=AaP1W3ZmdztTiKkh&t=162>

5) Disable WiFi Auto-join to your local network:

<https://youtu.be/9vM95hIBW-c?si=xnFNmgoxQUGXkSbJ&t=18>

Check your WLAN settings under:

Settings > Maintenance > Support Info > System Config > Show System Config

Ignition Timing

Assuming you want this ignition curve:

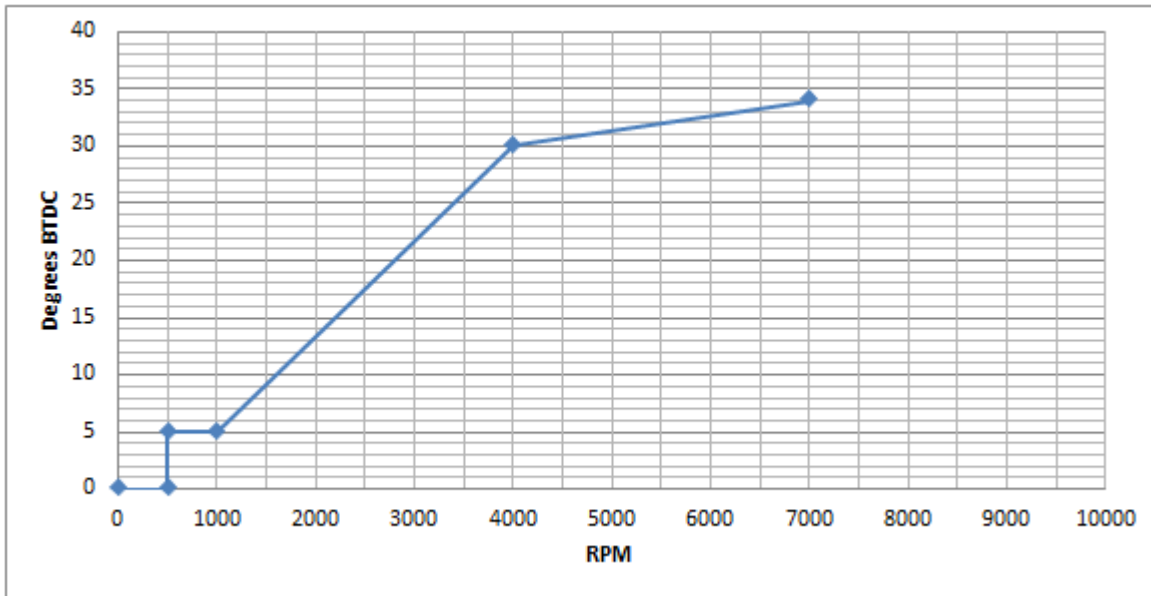

One can define the curve with 4 points but you can use up to 13 points.

(0 to 500rpm at 0° BTDC is hard coded for no kickback.)

The curve above is defined by 4 pairs of values

500 rpm	=	5°	BTDC
1000 rpm	=	5°	BTDC
4000 rpm	=	30°	BTDC
7000 rpm	=	34°	BTDC

Those 4 couples of values **MUST** be filled out in the form consecutively and in ascending order of RPM along with the pickup position.

Use this Windows software to draw the curve: [Interactive Graph.exe](#) with [Video](#)

Pickup Type

Default: 0

MENU	PICKUP TYPE	PICKUP POSITION
STROKES	SHAFT	CYLINDERS
ADVANCE TIMING	ADVANCE 0-500rpm	AUTO SPARK
DWELL	BYPASS	CONSOLE
MODIFY	UPDATE	

[0]

- 0: Analog Pickup Coil (VR-PN)
- 1: Analog Pickup Coil (VR-NP)
- 2: Digital Hall Effect Sensor *

Send

* option

Select the type of pickup attached to the Ignition box:

When the **LEADING** edge of the magnet passes in front of the pickup coil, a wave is produced and another wave of opposite voltage is generated when the **FALLING** edge of the magnet leaves the pickup coil. Depending on the wiring, the first pulse at Leading Edge can be positive (then negative at Falling edge), or the exact opposite.

0 = VR stands for Variable Reluctor aka pickup coil/trigger coil (Analog signal) **Positive first (PN)**

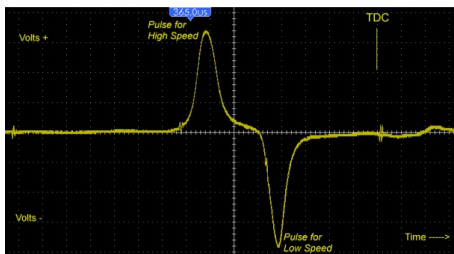

1 = Variable Reluctor (Analog signal) **Negative first (NP)**

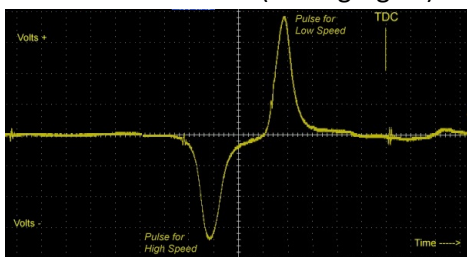

2 = Hall Effect Sensor (Digital signal)

This ignition box **works best with Positive first pickup (VR-PN)**

If the pickup is internally grounded into the stator there is no choice, the pickup output is either PN or NP
But if both pickup wires are available, then just [swap the wires](#) to change the polarity
in order to get a **Positive first signal (PN)** on connector **pin7**.

Pickup voltage

In order to be detected by the ignition, the VR pickup MUST deliver sufficient voltage.

The higher the RPM, the more voltage it should produce.

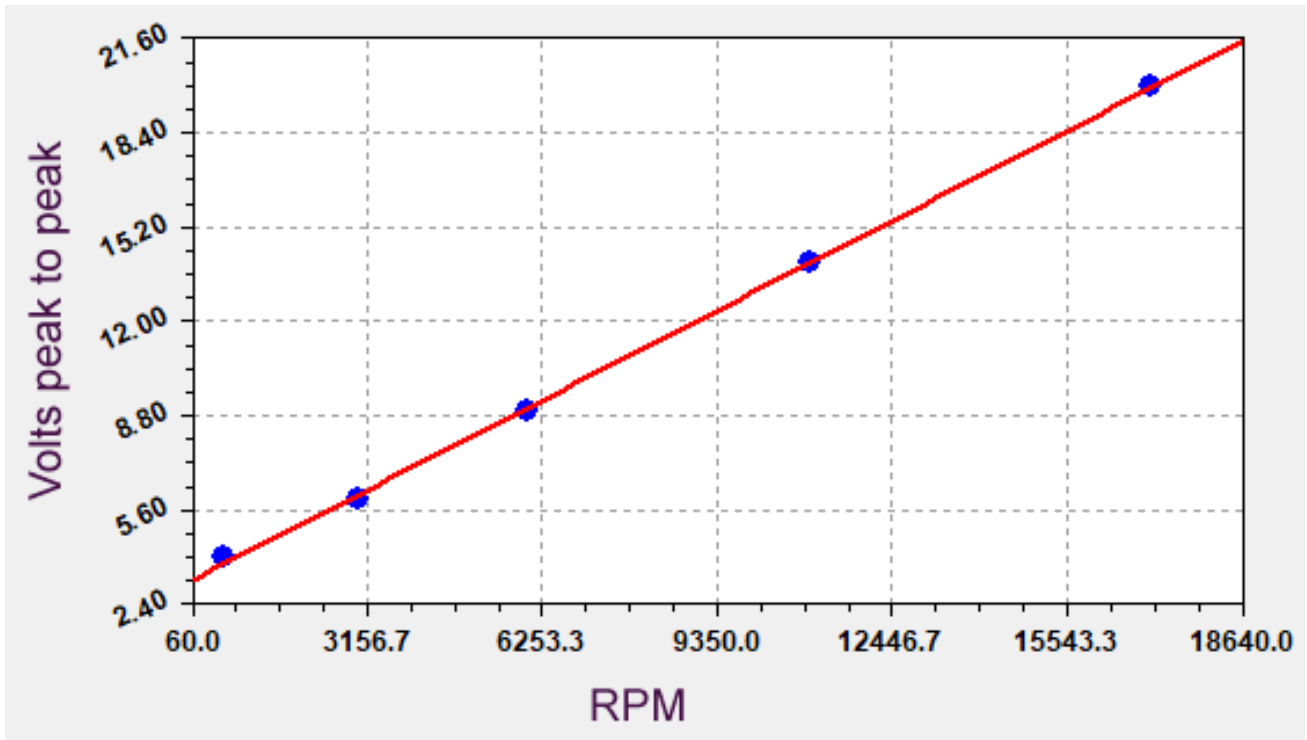

Formula :

Minimum Vpp voltage to be detected = RPM/1000 + 3

Example :

At **6000rpm** the VR pickup must put out :

$$6000/1000 = 6$$

$$6 + 3 = \mathbf{9Vpp}$$

9Vpp = +4.5v to -4.5v

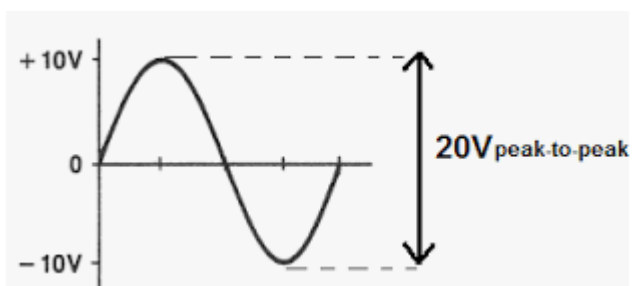

VR pickup

Analog VR pickup is connected between pin 7 and pin 8/gnd

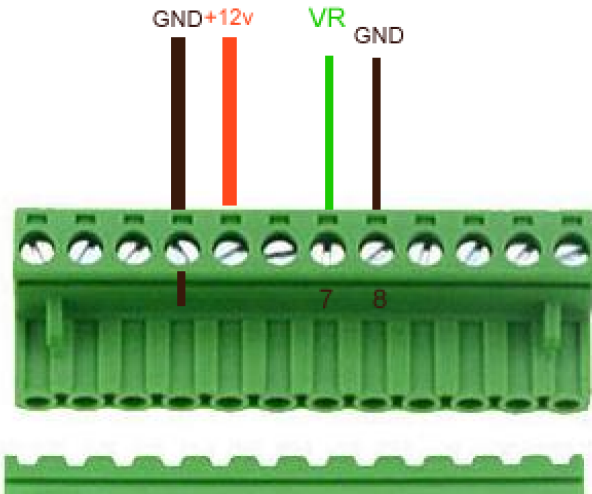

*To avoid ElectroMagnetic Interference (EMI) it's safer to connect the pickup sensor through a shielded cable.
Shield grounded on one side only.
Twisted pair is better.*

Hall Sensor

Digital Hall Sensor is connected between **pin 9** and **pin 8/gnd**

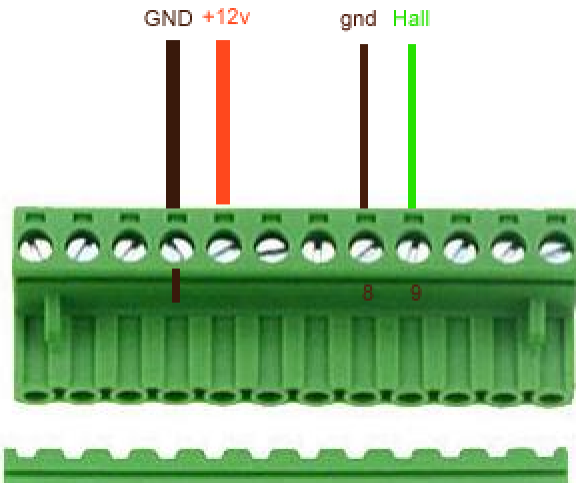

[Pickup Type](#) must be set to [2] for use of a Hall sensor.

2 types of Sensors

This ignition box only works with Hall sensors of **NPN** type.

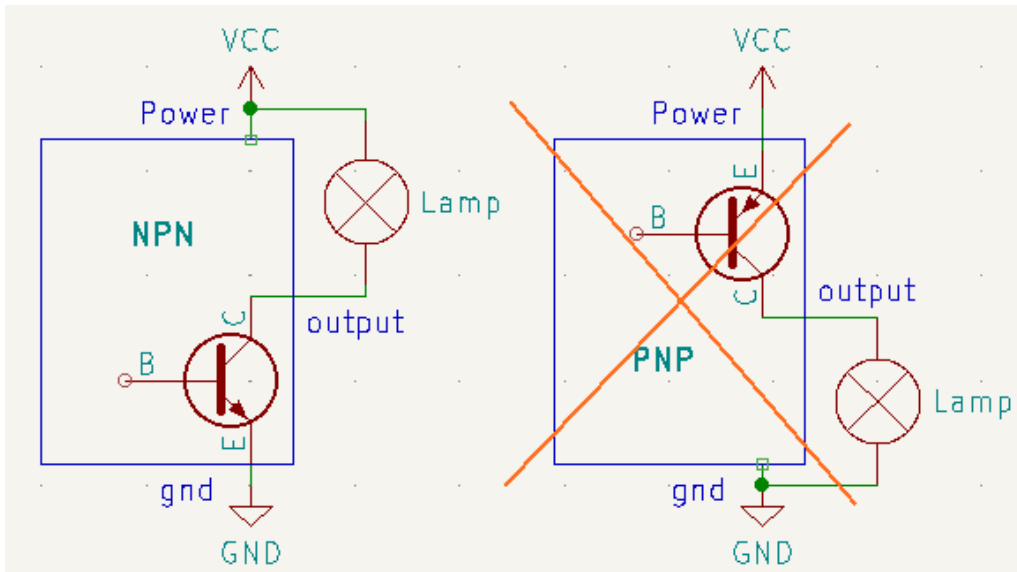

NPN Proximity Sensor Output is normally HIGH when nothing is near it.

NPN Proximity Sensor Output goes LOW when metal object is near it.

PNP Proximity Sensor Output is normally LOW when nothing is near it.

PNP Proximity Sensor Output goes HIGH when metal object is near it.

Tip: A PNP type can be used if there is an external NPN transistor to reverse the signal:

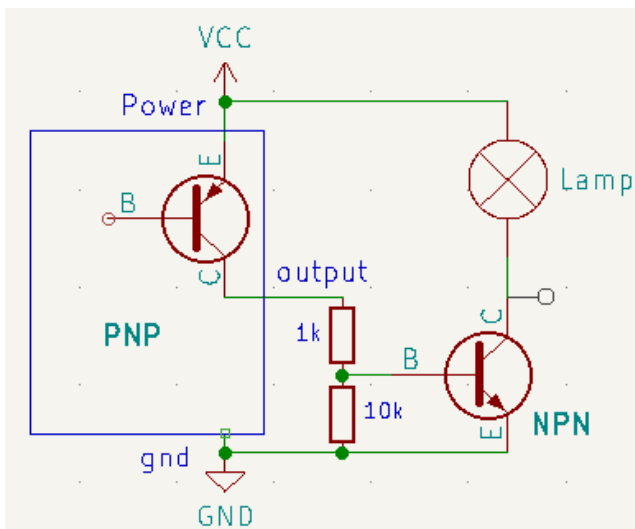

2 types of Output

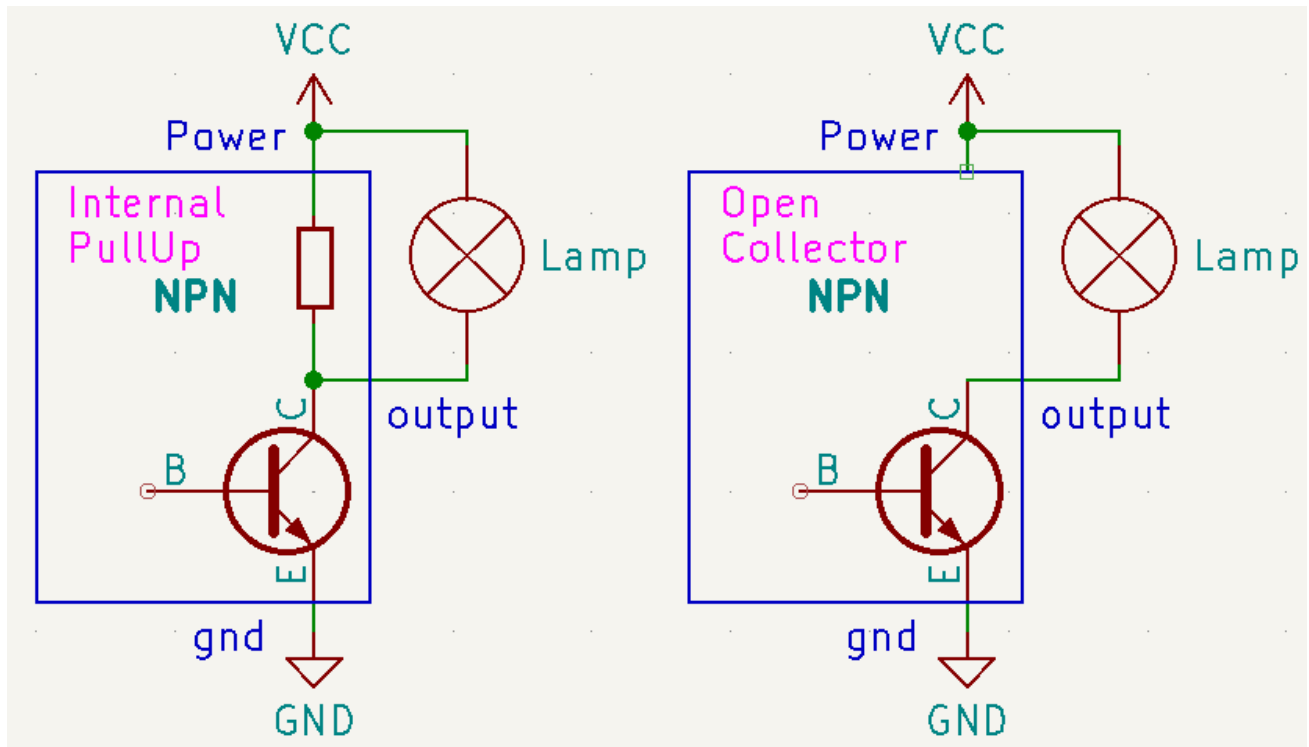

- Hall sensors with **built-in pull-up resistor** give positive voltage when no magnet.

- Hall sensors with **open-collector** output, give a floating voltage when no magnet.

This ignition box works with **both** type.

Hall sensors require a +5v to +12vdc supply voltage. *See their datasheet*

This ignition box works with Hall sensors powered from +5v to +24v

You can even connect an **Optical Sensor** as long as it puts out a **CLEAN** square signal similar to the one above.

See [Appendix 2](#) for Position

Output of a Hall sensor

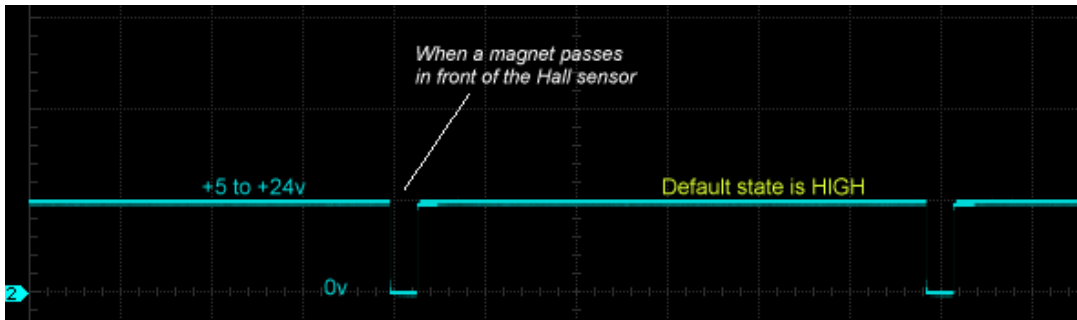

Timing

The ignition box uses the **rising edge** of the Hall sensor signal.



Troubleshooting

You can test the Hall input by making many fast and short touches between pin9/Hall and pin8/ground

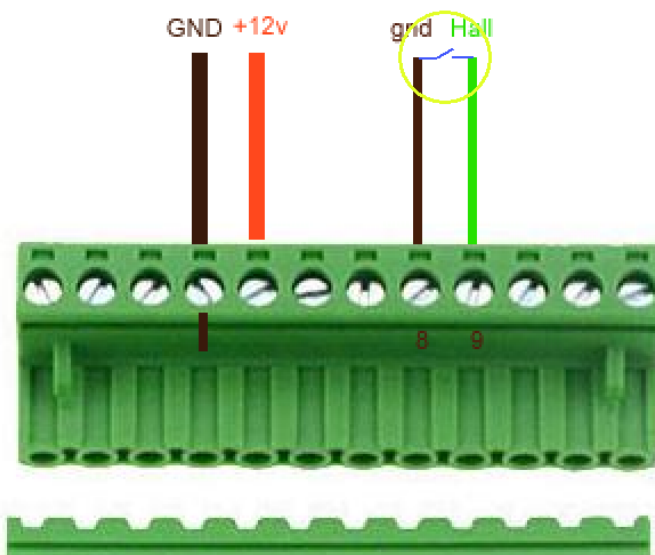

Pickup Position

Default: 50

Range of values: 1 to 180

MENU	PICKUP TYPE	PICKUP POSITION
STROKES	SHAFT	CYLINDERS
ADVANCE TIMING	ADVANCE 0-500rpm	AUTO SPARK
DWELL	BYPASS	CONSOLE
MODIFY		

[USERPOS]

BTDC

45 °

Send

- Go back to the opened browser and first thing first, enter the **Pickup Position** then click **Send**

Formula is: ***Pickup position = Base advance + Magnet Length***

Magnet Length:



Base advance is generally 5 to 15° BTDC

See [Appendix 1,2,3,4](#) to find the physical position of the pickup relative to TDC.

Current value appears in blue on the form.

Strokes

Default: 2

STROKES	SHAFT	CYLINDERS
ADVANCE TIMING	ADVANCE 0-500rpm	AUTO SPARK
DWELL	BYPASS	SECURITY
CONSOLE	MODIFY	UPDATE

[2]

- 2 strokes
- 4 strokes with Wasted Spark
- 4 strokes No Wasted Spark

Send

2 strokes : One pickup pulse every rotation
4 strokes with Wasted Spark : One pickup pulse every rotation = spark at TDC + wasted spark at BDC
4 strokes No Wasted Spark: One pickup pulse every 2 rotations = spark at TDC only

4 strokes with Wasted Spark is the most common case.

Shaft

Default: 0

MENU	PICKUP TYPE	PICKUP POSITION
STROKES	SHAFT	CYLINDERS
ADVANCE TIMING	ADVANCE 0-500rpm	AUTO SPARK
DWELL	BYPASS	CONSOLE
MODIFY		

[USERSFT]

- 0: CrankShaft
- 1: CamShaft
- 2: 2pulses/rev

Send

- Select if the pickup is placed :

- **0**: on the **crankshaft** via the flywheel (2stk) with 1 pulse per rotation
- **0**: on the **crankshaft** via the flywheel (4stk) with 1 pulse per rotation with wasted spark. (*one spark occurs during the compression stroke and another during the exhaust stroke.*)
- **1**: on the **camshaft** (4stk) with 1 pulse per 2 rotations.
- **2**: on the **crankshaft** with 2 pulses per rotation

Current value appears in blue on the form.

Advance Timing

- Proceed now to enter the advance timing.

We want to setup:

500 rpm = 5° BTDC
1000 rpm = 5° BTDC
4000 rpm = 30° BTDC
7000 rpm = 34° BTDC

Enter values consecutively in ascending order of RPM !

Pair 500:5 first etc etc...

7000 being the last value (as the firmware stops reading when it meets a null value),

7000 will act as the hard rev-limiter: No more sparks at 7001 RPM !

MENU	PICKUP TYPE	PICKUP POSITION
STROKES	SHAFT	CYLINDERS
ADVANCE TIMING	ADVANCE 0-500rpm	AUTO SPARK
DWELL	BYPASS	CONSOLE
MODIFY		

Stored Values:

Timing Curve 1:

0	500
4	5
8	1000
12	5
16	3000
20	40
24	8000
28	30
32	0
36	0
40	0
44	0

Curve N°1 or N°2*

USERTIM

RPM

3000

ADV

14°

Curve

0 (0=curve N°1)

Send

* Option

RPM can be entered with a 100rpm step but RPM will be measured with **1rpm** precision.

Timing can be entered with a precision of 1° but the processor calculate all timing values between the points you entered, using linear interpolation so an **accuracy of 0.1°** is done at this step.

Any timing values will be **COMPLETELY OFF** IF **PICKUP POSITION IS FALSE**: **PICKUP POSITION IS KEY**

See [Appendix 1](#) for Position

Curve N°1 is stored at addresses 0 to 100

Select curve

Default: curve N°1

If you bought the 2 curves option, then connect a switch between connector **pin 12 and ground**.

When switch is **open** (or no switch connected), **curve N°1** is used.

If switch is **on** (*pin 12 connected to ground*) BEFORE turning on the ignition box, then **curve N°2** will be used.

You cannot change the curve while running. (*The switch is not read by the ignition*)

MENU	PICKUP TYPE	PICKUP POSITION
STROKES	SHAFT	CYLINDERS
ADVANCE TIMING	ADVANCE 0-500rpm	AUTO SPARK
DWELL	BYPASS	CONSOLE
MODIFY		

Curve N°1 or N°2*

500 => 14

RPM

3000

ADV

14 °

Curve

1 (0=curve N°1)

Send

* Option

96	0
100	0

Timing Curve 2:

104	501
108	5
112	1001
116	8
120	3001
124	30
128	10001
132	40
136	0
140	0
144	0
148	0
152	0
156	0
160	0
164	0
168	0
172	0
176	0
180	0
184	0
188	0
192	0
196	0
200	0
204	0

Settings:

Curve N°2 is stored at addresses 104 to 204

Read

- To display the values that have been set, click on the **Read** button on the **Home** page :

Stored Values:

Timing Curve:

0	500
4	5
8	1000
12	5
16	4000
20	30
24	7000
28	34
32	0
36	0
40	0
44	0
48	0
52	0
56	0
60	0
64	0
68	0
72	0
76	0
80	0
84	0
88	0
92	0
96	0
100	0



Stored Values:

Timing Curve:

0	500
4	5
8	1000
12	5
16	4000
20	30
24	0
28	0
32	0
36	0
40	7000
44	34
48	0
52	0
56	0
60	0
64	0
68	0
72	0
76	0
80	0
84	0
88	0
92	0
96	0
100	0



92	0	196	0
96	0	200	0
100	0	204	0

Settings:

212	400	Kick Speed (AC/DCCDI)
216	50	Pickup Position (^btdc)
232	0	Pickup Type (0:VR)
233	3	Dwell (TCI)
234	0	DwellType (TCI)
235	0	
236	0	Adv 0-500rpm (^atdc)
237	0	Console output (0:No)
238	0	HV Boost (DCCDI)
239	0	Shaft (0=crankshaft)
240	0	Autospark (TCI/DCCDI)
241	0	
242	0	
243	0	Bypass (TCI)
244	1	Cylinders
245	2	Strokes
248	2	Starts

All values must be consecutive and in ascending order of RPM !

Dump

Read EEPROM addresses and display them in HEX values for debug purpose.

MENU	PICKUP TYPE	PICKUP POSITION
STROKES	SHAFT	CYLINDERS
ADVANCE TIMING	ADVANCE 0-500rpm	AUTO SPARK
DWELL	BYPASS	CONSOLE
MODIFY		

Read
Dump
Home
Clear Timing
Clear All
Factory Restore

Dump EEPROM Hex Values:

0	F4	01	00	00	05	00	00	00
8	40	1F	00	00	28	00	00	00
16	34	21	00	00	28	00	00	00
24	00	00	00	00	00	00	00	00
32	00	00	00	00	00	00	00	00
40	00	00	00	00	00	00	00	00
48	00	00	00	00	00	00	00	00
56	00	00	00	00	00	00	00	00
64	00	00	00	00	00	00	00	00
72	00	00	00	00	00	00	00	00
80	00	00	00	00	00	00	00	00
88	00	00	00	00	00	00	00	00
96	00	00	00	00	00	00	00	00
104	00	00	00	00	00	00	00	00
112	00	00	00	00	00	00	00	00
120	00	00	00	00	00	00	00	00
128	00	00	00	00	00	00	00	00
136	FE	00	00	00	00	00	00	00
144	00	00	00	00	00	00	00	00
152	00	00	00	00	00	00	00	00
160	00	00	00	00	00	00	00	00
168	00	00	00	00	00	00	00	00
176	00	00	00	00	00	00	00	00
184	00	00	00	00	00	00	00	00
192	00	00	00	00	00	00	00	00
200	00	00	00	00	00	00	00	00
208	00	00	00	00	00	00	00	00
216	32	00	00	00	00	00	00	00
224	02	00	00	00	00	00	00	00
232	00	00	00	00	00	00	00	00
240	00	00	00	00	01	00	00	00

Home

Modification

LINE

NEW VALUE

Say you want to modify the advance timing for 7000rpm and set 35° instead of 34°

In *Read* mode above, we saw that RPM 7000 is stored at address 24 and timing for 7000rpm is at address 28.

24	7000
28	34
32	0

Since we want to modify the advance timing at line 28, we now have to enter :

Line **28**
New value **35**
then **Send**

LINE

NEW VALUE

Same thing to change any other values.

Remember: All timing values must be in ascending order of RPM and no blank address between timing values.

Use [Read](#) button to check that.

Add points

Say you want **to add** one advance timing of 34° @ 8000rpm

In *Read* mode above, we saw that last RPM 7000 is stored at address 24 and timing for 7000rpm is at address 28.

The next 2 empty slots available are:

24	7000
28	34
32	0
36	0
40	0

Address **32** for RPM and Address **36** for timing

We now have to enter :

Line **32**
New value **8000**
then **Send**

Line **36**
New value **34**
then **Send**

Remember: All timing values must be **consecutive** and in **ascending order of RPM** !

Use [Read](#) button to check that.

Clear points

Say you want to remove the last advance timing of 34° @ 7000rpm

In *Read* mode above, we saw that last RPM 7000 is stored at address 24 and timing for 7000rpm is at address 28.

24	7000
28	34
32	0
36	0
40	0

To zero out those values we now have to enter :

Line **24**
New value **0**
then **Send**

Line **28**
New value **0**
then **Send**

Remember: All timing values must be consecutive and in ascending order of RPM !

Use [Read](#) button to check that.

Stored Values:

Timing Curve:

0	500
4	5
8	1000
12	5
16	4000
20	30
24	0
28	0
32	0
36	0
40	7000
44	34
48	0
52	0
56	0
60	0
64	0
68	0
72	0
76	0
80	0
84	0
88	0
92	0
96	0
100	0



exit

Clear Timing

This button will **clear TIMING values** WITHOUT confirmation.

Pickup position, polarity, shaft, dwell etc are kept.

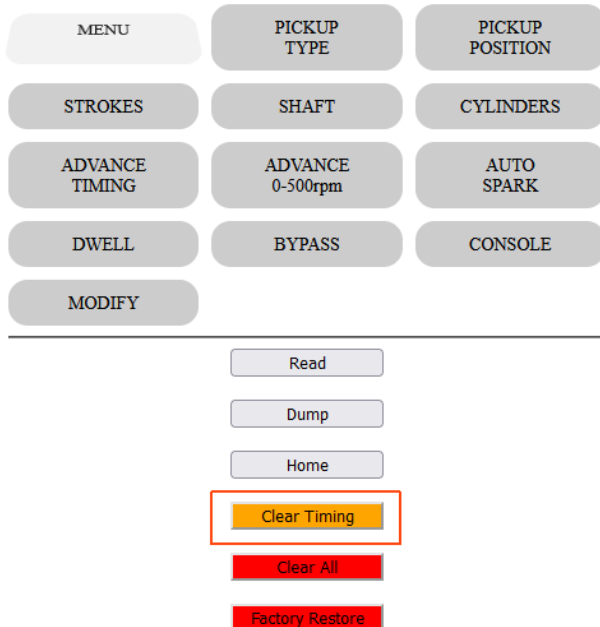

Browser shows :

Timing values cleared!

Please restart the ignition box.

This box now has no Advance Curve and cannot operate until you set timing values.

Restart the ignition box. (power off/power on)

Don't forget the Kill switch position if you want to return in Setup mode....

Clear All

This button will **clear ALL values** WITHOUT confirmation.
Timing, Pickup position, polarity, shaft, dwell etc are zeroed.

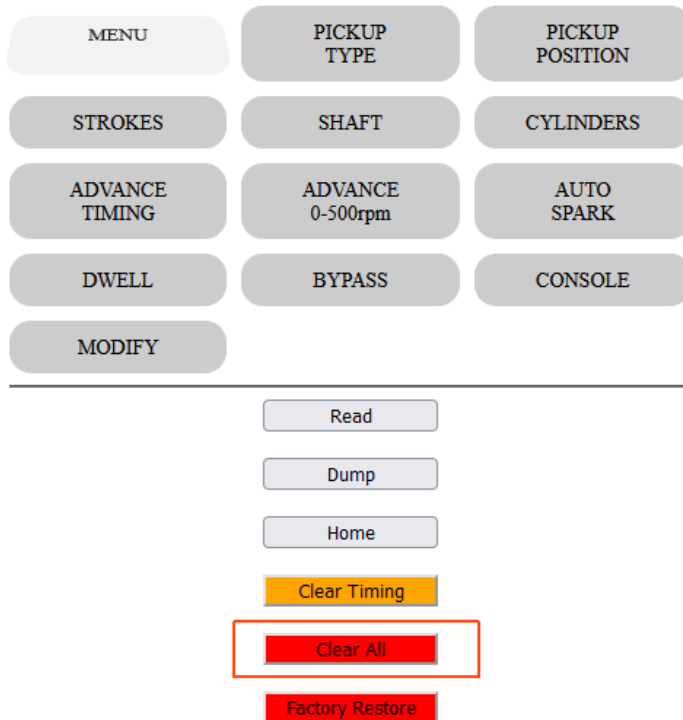

Browser shows :

EEPROM values cleared!

Please restart the ignition box.

This box is now *empty* and cannot operate until you set values. '

Restart the ignition box. (power off/power on)

Don't forget the Kill switch position if you want to return in Setup mode....

Factory Restore

This button will **Restore Factory Default** WITHOUT confirmation.

Timing, Pickup position, polarity, shaft, dwell etc are set to default values.

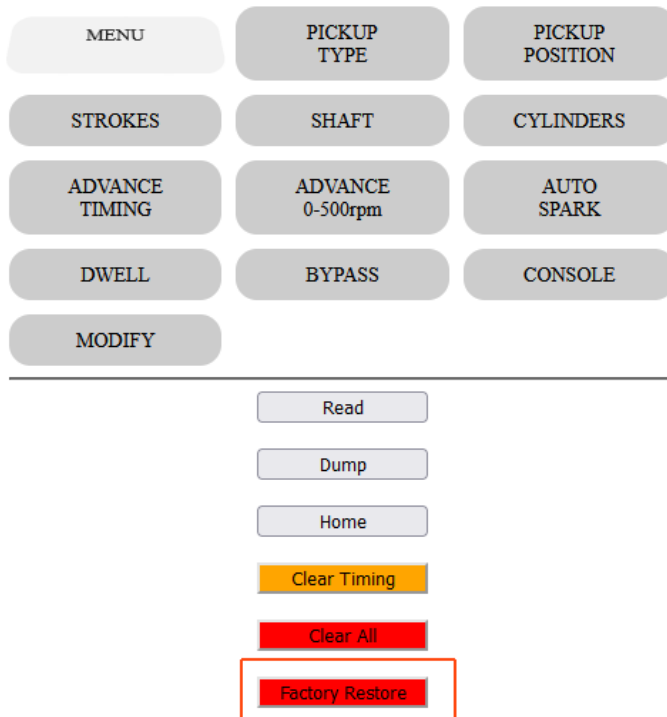

Browser shows :

Init All done!

**This box now have a default Advance Curve which is not the one you need...
Tune the values before to start the engine!**

Restart the ignition box. (power off/power on)

Don't forget the Kill switch position if you want to return in Setup mode....

Advanced settings

If you don't need those Extra settings, just let them to their default value.

Advance at kick start

Default: 0

Range of values: 0 to 10

For an easier Manual Kick start and to avoid kick backs, you can delay the advance between 0 to 500rpm to send the spark a few degrees **After** Top Dead Center (ATDC)

MENU	PICKUP TYPE	PICKUP POSITION
STROKES	SHAFT	CYLINDERS
ADVANCE TIMING	ADVANCE 0-500rpm	AUTO SPARK
DWELL	BYPASS	CONSOLE
MODIFY		

[0]

ATDC

Send

Current value appears in blue on the form.

Tech info:

If the measured period/rpm is less than 500rpm, the CPU uses the measured rpm (ie 320rpm) to determine when the next TDC will append during the next revolution, assuming the rpm remains constant.

If the engine speed decrease due to low inertia, the TDC calculation will be incorrect, resulting in an early spark.

To address this issue, the CPU adds an offset to the calculation, which equals the value of the "Advance 0-500" tab that the user may have set.

i.e., if the user specifies 20° ATDC, the CPU will calculate the theoretical next TDC and add 20° to the result.

If the measured rpm is over 500rpm, the CPU read the advance timing map the user has set to find which advance must be applied for this specific RPM (ie520rpm). No user offset will be used.

AutoSpark

Default: Off

Range of values: Off, 300 1000, 3000, 10000rpm

This **autotest function** is usable on TCI and DCCDI only.

The ignition box fires the ignition by itself at 300/1000/3000/10000rpm WITHOUT any pickup connected.

This way you can test the wiring, the TCI/DCCDI, the ignition coil and sparkplug.

Of course, remove the sparkplug from the cylinder head and connect it's metal part to the bike frame.

ADVANCE TIMING N°2	DWELL	AUTOSPARK
CONSOLE	BYPASS	MODIFY

[0]

- 0: Off
- 1: 300rpm
- 2: 1000rpm
- 3: 3000rpm
- 4: 10000rpm

Send

Current value appears in blue on the form.

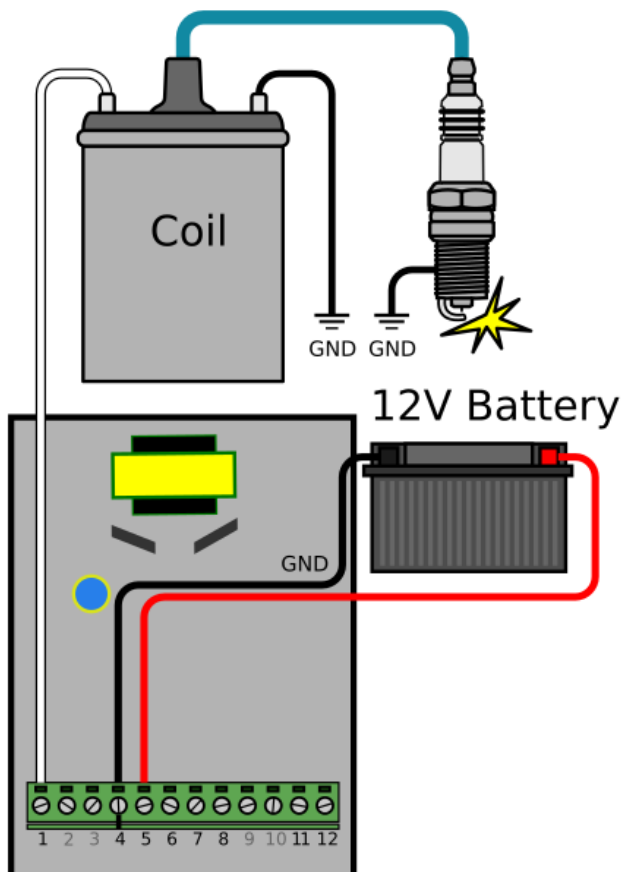

Kick Speed

Default: 800

Range of values: 100 to 1000rpm

For an easier Manual Kick start and to avoid kick backs, you can select what will be the RPM of the very first engine rotation when it is kick started.

The image shows a control panel with six buttons arranged in two rows. The top row contains 'ADVANCE 0-500rpm', 'AUTO SPARK', and 'KICKSP' (which is highlighted in grey). The bottom row contains 'DCCDI', 'CONSOLE', and 'MODIFY'. Below the buttons is a blue value '[800]'. Underneath that is a label 'Kick Speed' followed by a text input field with a dropdown arrow and the unit 'rpm'. Below the input field is a 'Send' button.

Current value appears in blue on the form.

Tech info:

When a trigger signal comes (pickup or hall), the CPU measures the time between this pulse and the preceding one to determine the period, and hence the rpm.

At the very first pulse only, as there is no previous one, the period is unknown.

The CPU then uses the "kick speed" rpm (default 400rpm) or any other value the user may have specify.

The "kick speed" value will not be used for the following pulses because the period will be calculated based on two consecutive trigger pulses.

If there is more than 1sec between 2 pickup pulses, "kick speed" setting will be applied again for the next first pulse.

DC-CDI

Default: 0

The DC converter output voltage is set to 180Vdc by default.

Set to "1" charges the internal capacitor to 300Vdc for a boost effect!

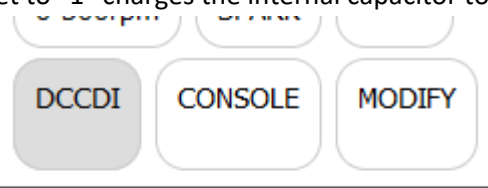

[0]

- 0: 180v
- 1: 300v (boost)

Send

Current value appears in blue on the form.

Yellow: pickup signal blue boosted DC converter voltage, Pink default voltage.

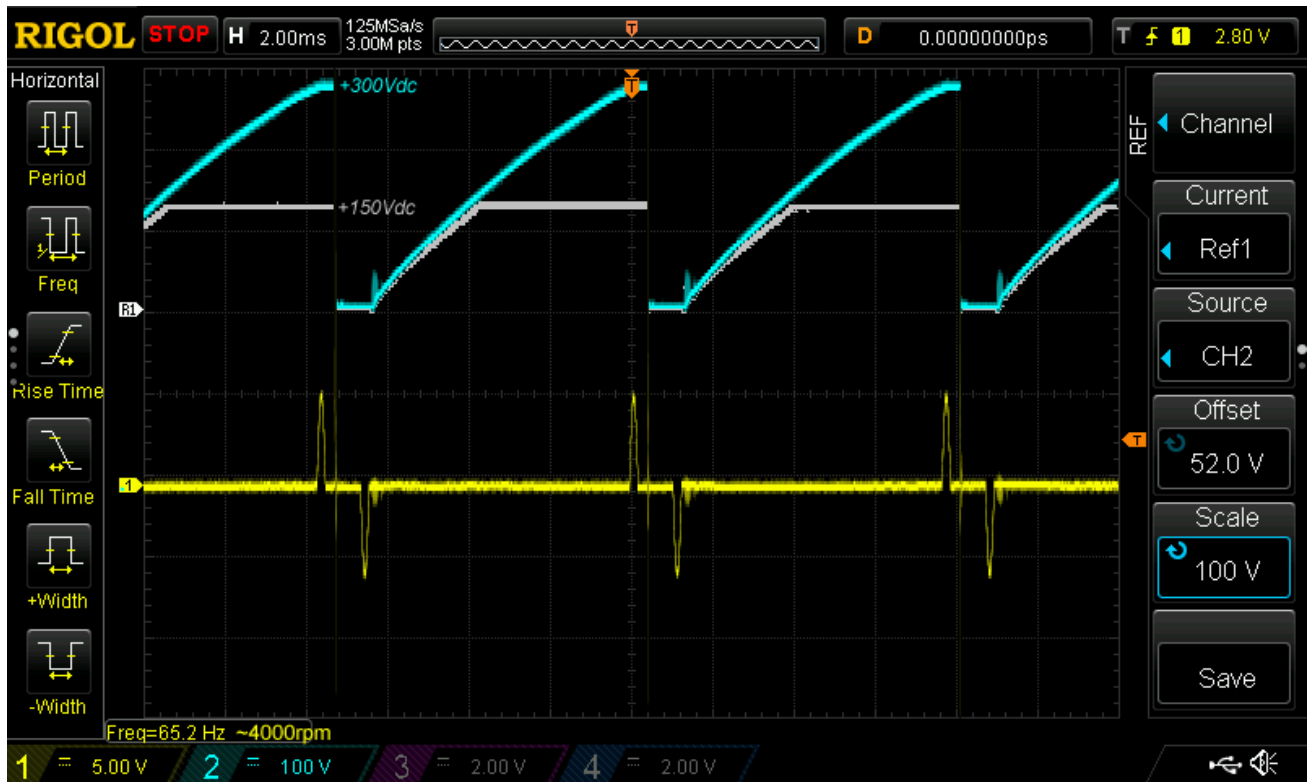

(In Autospark mode, the voltage is always 300V)

Test Point

This DC-CDI ignition contains a DC converter ("*a transformer*") that transform a +12Vdc voltage into a 150Vdc or 300Vdc voltage.

This tension is available to measurement at pin 3. (**!/ Beware of Electric Shock**)

To check the voltage:

- Turn off the DCCDI
- Connect a DC multimeter between ground pin 4 and TestPoint pin 3 in at least 350Vdc position.
- Turn on the DCCDI

DCCDI powered on, engine stopped	0Vdc
DCCDI powered on, engine running	150Vdc or 300Vdc depending on Settings
DCCDI powered on, Autospark mode 300rpm	300Vdc

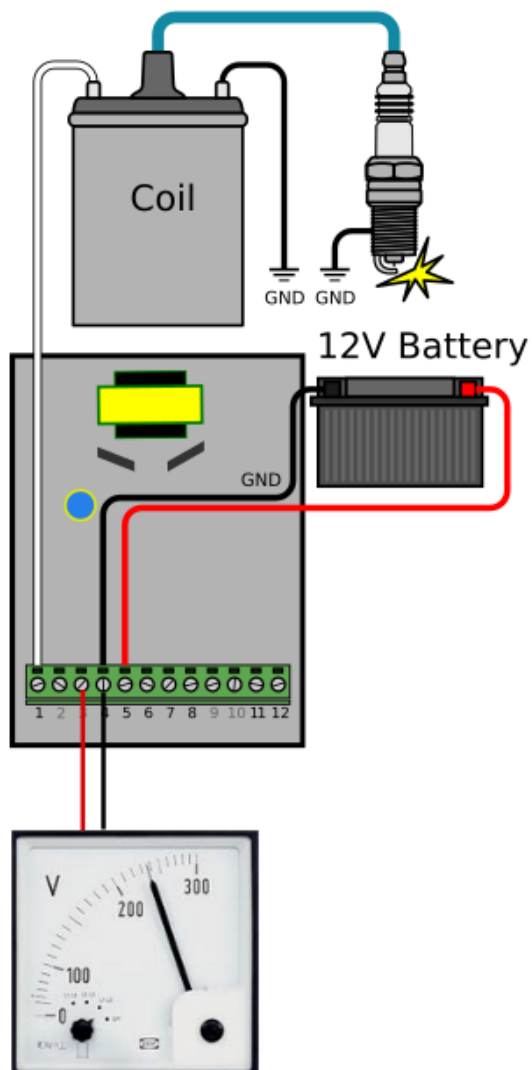

Console

Default: Off

Enable the Console output:

- Turn the ignition box in [Setup Mode](#)

- Go to "**CONSOLE**", check "1" to enable the console output, press Send

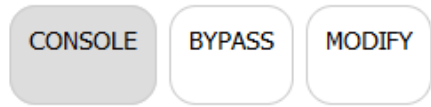

[0]

- 0: Off
- 1: On

Send

Current value appears in blue on the form.

- Power **off** the ignition box
- **Disconnect** the **Kill** wire from ground

1) **Power on** the ignition box, it goes in "**Run Mode**"

2) The **blue LED** flashes once if curve N°1 is selected or flashes twice for curve N°2

4) The ignition box also creates a **WiFi AP** (*Access Point*)

5) On your phone, laptop, PC, whatever, go to the **Wifi setting** and search for a new SSID called **Transmic_ign**
You can see available SSID with a Wifi Analyzer as [NetSpot for Android](#) or [Wifi-Analyzer for W10](#)

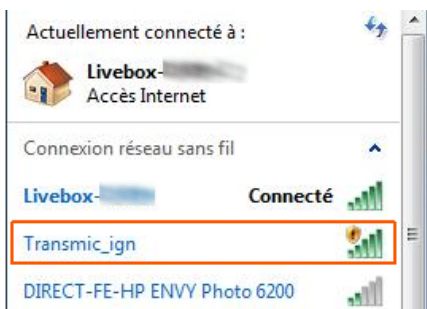

6) **Connect** to it

From CDIV12r0 to CDIV12r2 *no password* was required

Up from CDIV12r3 password is required: it's "**password**"

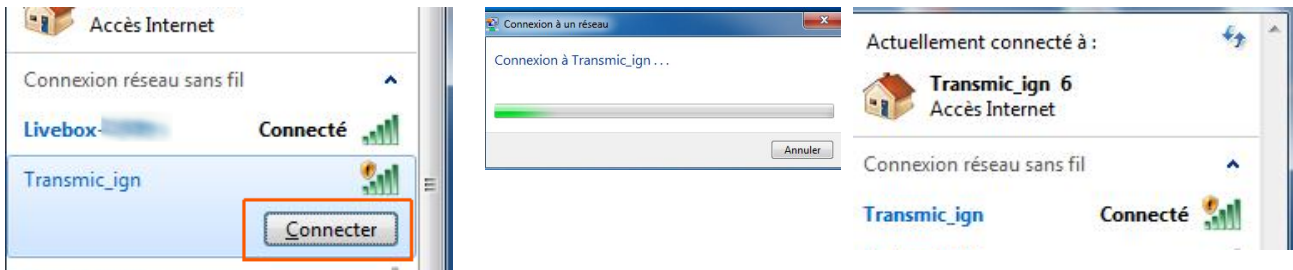

7) **Start** the engine

8) Once your device is connected to the AP, open up a **browser** and type in the address bar:

- Until version ACDCCDIV12r3c3:

<http://192.168.4.1>

- From version ACDCCDIV12r4c0 (August2023) :

<http://192.168.4.1/console>

9) After a few seconds, the browser should display both the **RPM and the advance timing** in degrees BTDC followed by 2 bargraphs

RPM vs ADV

3360

39.29



Display appears ONLY when the engine is running.

Because of the impact on Ignition box performance, please use it for debug only and disable this function when you are done with it!

Troubleshooting

Console URL is `http://` NOT `https://` but some browsers like Chrome automatically switch to `https://`

Workarounds

- Use Firefox. Close all Firefox windows than relaunch it.
- Use a lightweight, portable browser as [QtWeb](#)
- In Chrome, disable **HSTS** (*HTTP Strict Transport Security*) that forces to open websites in HTTPS:
 - Write `chrome://net-internals/#hsts` in the address bar.
 - Scroll down the page to :

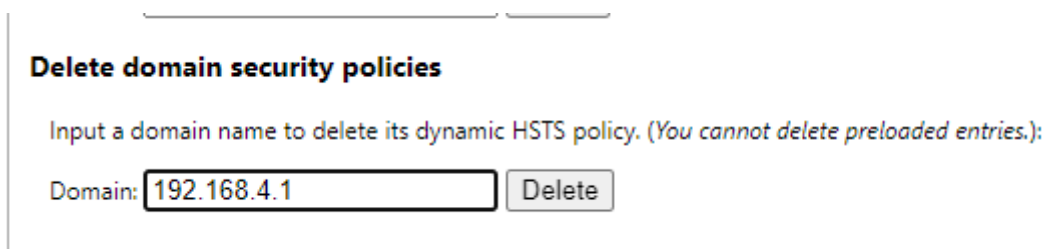

- add **192.168.4.1** and hit **Delete** to disable Force https for this particular website.

Running Mode

- 1) **Disconnect** the **Kill** wire from ground if you previously went into [Setup Mode](#)
- 2) **Power on** the ignition box, it goes in "**Run Mode**"
- 3) The **blue LED** flashes one time.
- 4) Start the engine. The blue LED **blinks** in sync **with RPM**.
- 5) When the engine runs, if **Kill** wire is connected **to ground** THEN it **stops** the engine.

Appendix 1

Case of Variable Reluctor aka VR pickup/pickup coil/trigger coil

(For Hall sensor, read [Appendix2](#))

In the example below the pickup/sensor is set at 39° BTDC

Method N°1 Pickup aligned with rising edge

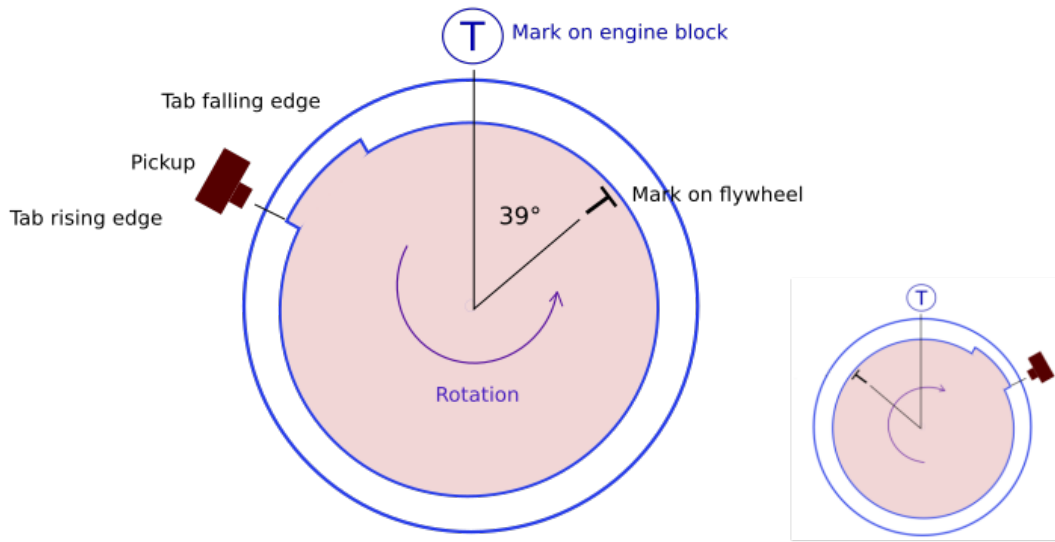

Method N°2 Engine at TDC

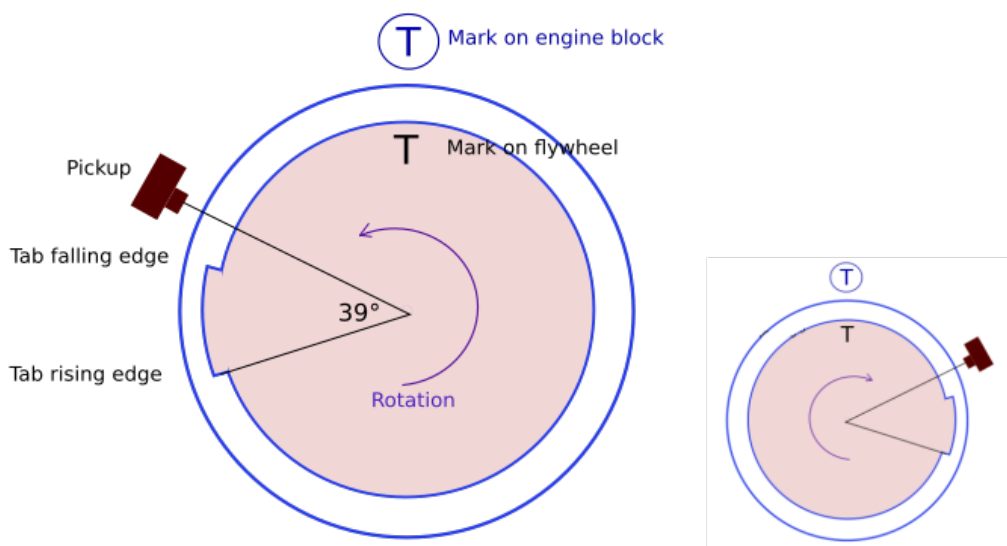

Leading|Rising edge generate pulse for high revs
Trailing|Falling edge generate pulse for idle.

calageTDC_pickup_2methods.svg

Appendix 2

Case of Hall Effect Sensor

(For VR pickup/analog pickup read [Appendix1](#))

Find the physical position of the digital **Hall Sensor** relative to Top Dead Center.

In the example below the sensor is set at 39° BTDC

Method N°1

Hall sensor aligned with falling edge

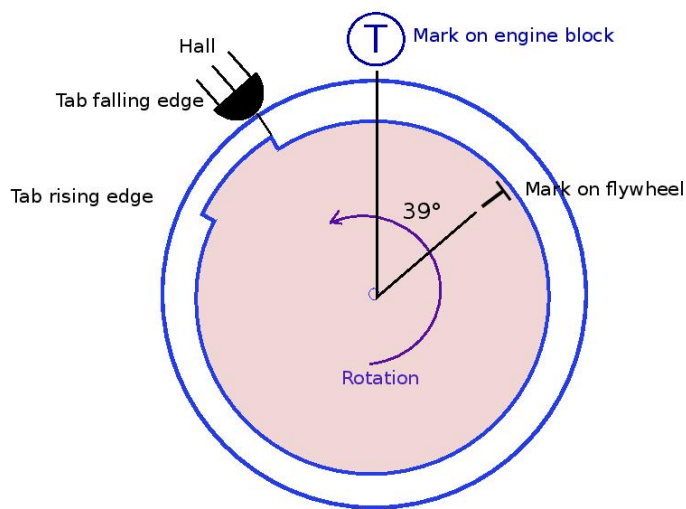

Method N°2

Engine at TDC

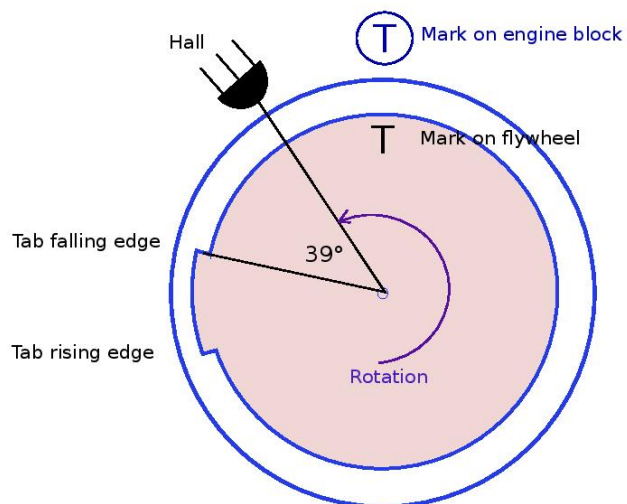

Appendix 3

A) Remove the sparkplug, find the TDC position with a *dial indicator gauge* or a *caliper rule*:



B) Align the pickup with the beginning of the magnet on the rotor and measure the travel of the piston with the caliper rule:

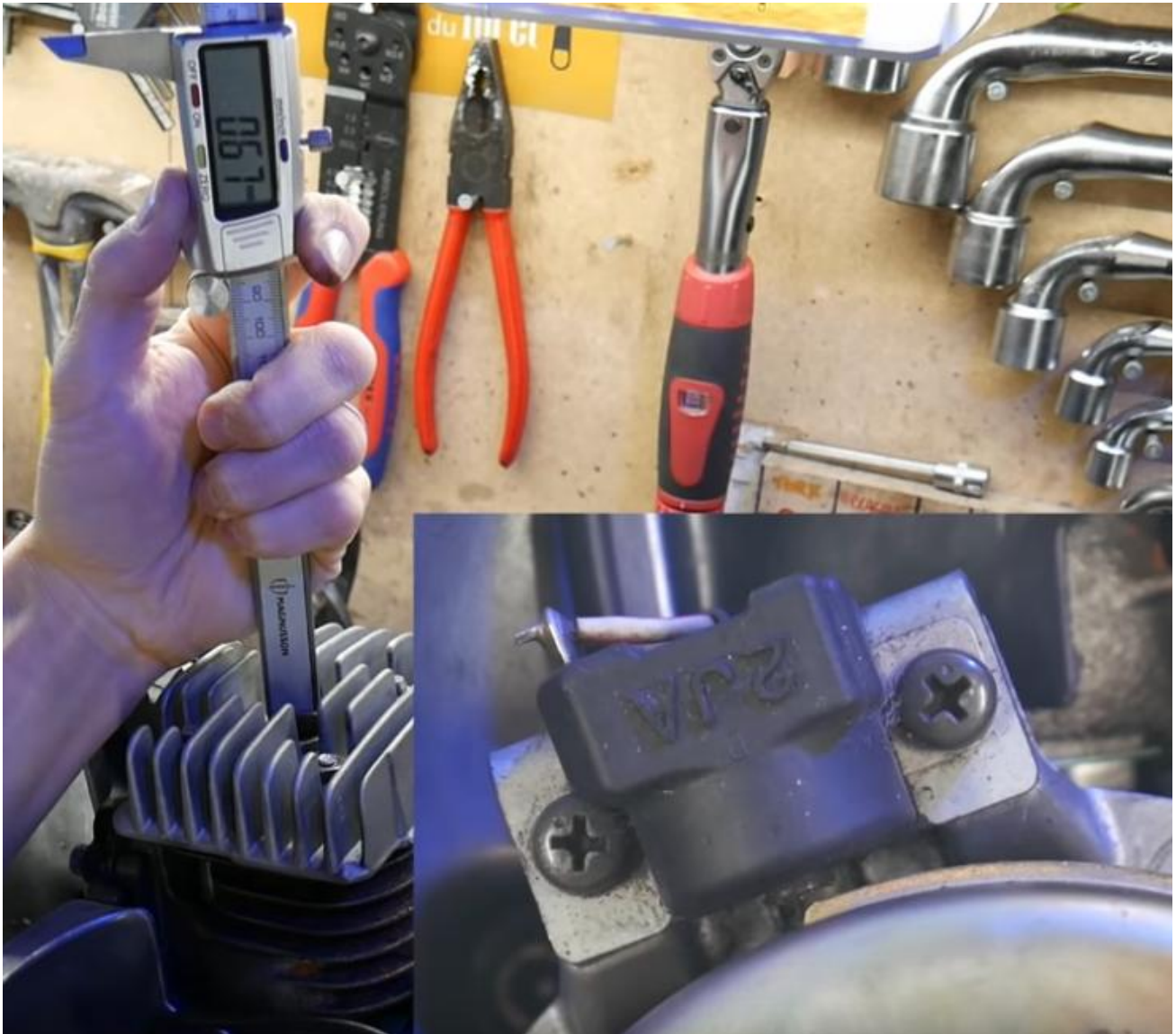

C) Use an online timing calculator to convert millimeters into degrees:

<https://lambretta-images.com/tuningh/port-timing-calculators/degrees-to-mm-timing-calculator/>

or

<http://www.ajcshop.fr/Calculettes/html/calculette-convertisseur-allumage.htm>

ie:

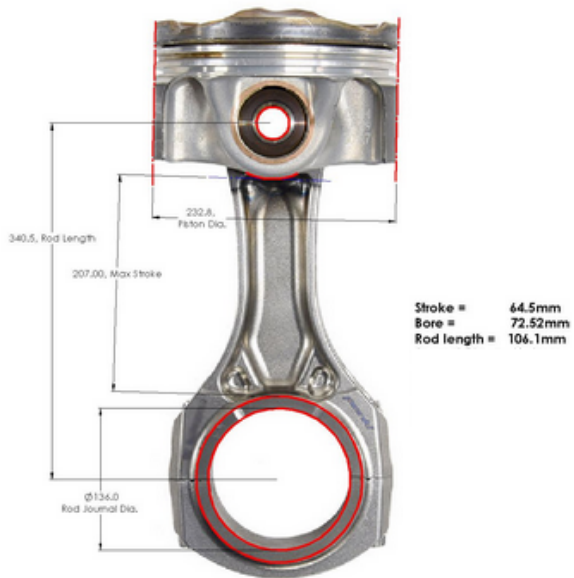

=>

1	->	64.5	Course en mm
2	->	106.1	Longueur de bielle (entraxe) en mm
3	->		Diamètre (D) du volant en mm (uniquement)
4	->	0.67	Avance en mm
			Avance en degrés (angle α) (renseigner 1, 2, 4) <u>Le résultat est en ° et centièmes de °</u>
Calculer		10.25	

Appendix 4

Tries and errors and Timing Lamp



If there is no mark on the flywheel, a possible way is as follows:

Method:

Remove the spark plug, insert a gauge in the sparkplug hole.
Turn the flywheel until the piston is at TDC. Remove the gauge.

Draw 2 marks opposite each other on the flywheel and on the engine case. It's the TDC mark.

Print a *Timing Tape* from <https://www.blocklayer.com/timing-tape>
Align the 0 mark to the new TDC mark and stick the tape on the flywheel.

Set the ignition box with a pickup position of say 30° BTDC

Set the ignition box with a SAFE and FLAT timing curve at a static advance (ie : 10° BTDC from 500 to 4000rpm)

Put back the sparkplug and start the engine if possible
Otherwise plug the sparkplug in it's cap, tied the plug to the frame to have sparks, then rotate the engine with a drill machine (the faster the better).

With a timing lamp, take note where on the timing tape the spark appends.

Take note how much "off" is the timing.

Examples :

If the timing lamp shows 15° BTDC (instead of 10°) that mean the "*Pickup Position*" is off by 5° (15°-10°).

The pickup position is the off by 5°. Increase the "*Pickup Position*" by 5. Real position is not 30° but $30° + 5° = 35°$

Set the ignition box with a pickup position of 35° BTDC

Using the timing lamp, check that the timing is now read at 10°

Make small adjustment to the pkp position if necessary.

If the timing lamp shows 5° BTDC (instead of 10°) that mean the "*Pickup Position*" is off by -5° (5°-10°).

The pickup position is the off by -5°. Lower the "*Pickup Position*" by 5. Real position is not 30° but $30° - 5° = 25°$

Set the ignition box with a pickup position of 25° BTDC

Using the timing lamp, check that the timing is now read at 10°

Make small adjustment to the pkp position if necessary.

In one word:

If the Timing Lamp measure MORE advance than what is set in the user interface then INCREASE the "*Pickup position*"

If the Timing Lamp measure LESS advance than what is set in the user interface then LOWER the "*Pickup position*"